

REV 更改号	DATE 日期	REVISION DETAILS 更改内容	APPD 审核并批准
A	OCT. 08. 2019	Production issue	
B	Nov.22	Change the file name from	Zhang

41338-M10-2NPSF to 41338-M12-2NPSF

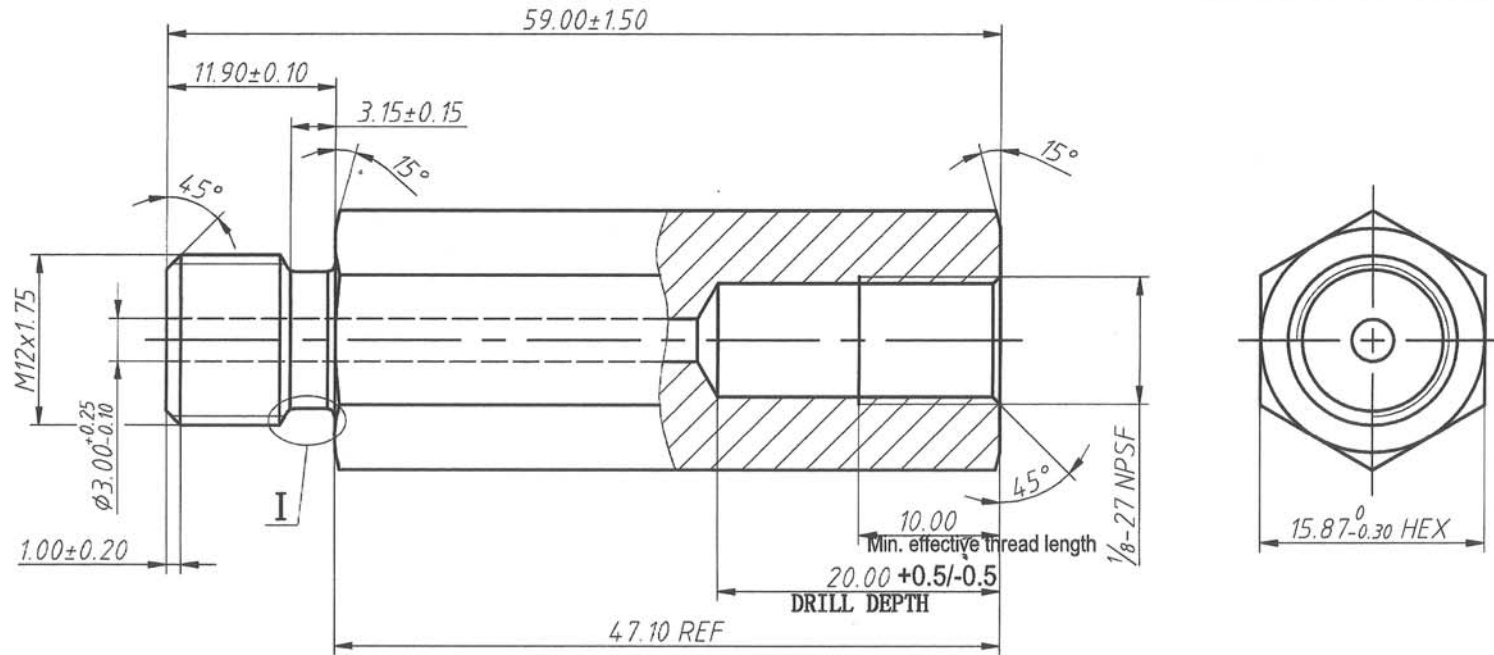

UNLESS SPECIFIED  
ALL DIMENSIONS IN mm,  
MACHINED SURFACES  $Ra=3.2\mu m$ ,  
ANGLE TOLERANCES  $\pm 5^\circ$ ,  
Other tolerance except angles,  
in accordance with  
GB/T1804-2000(ISO2768-1)-m  
and GB/T1184-1996(ISO2768-2)-m

其它事项,  
图示尺寸单位为mm,  
未注机加工表面粗糙度  $Ra=3.2\mu m$ ,  
未注角度公差  $\pm 5^\circ$ ,  
其它未注公差 (除角度外) 均按:  
GB/T1804-2000(ISO2768-1)-m 和  
GB/T1184-1996(ISO2768-2)-m

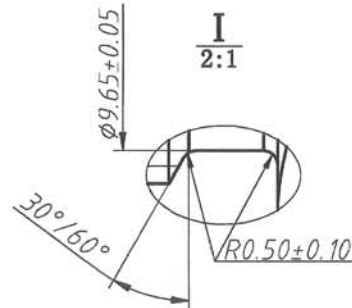

Zhejiang Gaocheng Autoparts Co.,Ltd	
PART No 零件名	41338-M12-2NPSF
SCALE:	批准 Zhang
DATE:	制图 余德胜
NTS	日期 2019. 10. 08
	审核 詹永斌

MATERIAL	Chinese steel 45	材质 45#
FINISH	Remove all sharp edges,burrs,slivers and swarf, break all edges 0.127-0.254mm. ZINC PLATING WITH 8um MICRONS MINIMUM PLATING THICKNESS AND TRIVALENT CHROMATE PASSIVATION AND WITHSTAND 96 HRS TO WHITE / 144 HS TO RED RUST IN SALT SPRAY TEST.	去除所有毛刺, 铁屑等残留物, 锐边倒钝0.127-0.254mm. 镀锌, 三价铬钝化, 银白色, 盐雾试验96小时无白斑, 144小时无红锈, 镀锌层厚度大于8um.